

# DAIMLER TRUCK

## Evento “A Evolução do Mercado de H2V no Brasil” | O caminhão Mercedes-Benz movido a Hidrogênio - GenH2 Truck

João Marcos Costa | Product Development Manager

Mercedes-Benz do Brasil | Daimler Truck

19.09.2023



FREIGHTLINER®

FUSO

WESTERN STAR

Thomas  
BUILT BUSES

BHARATBENZ

SETRA

# Agenda

1

**Transformation path towards Zero Emission Transportation**

2

**Daimler Truck Zero Emission portfolio**

3

**GenH2 Truck**

| Hydrogen-based FuelCell Electric Truck from Daimler Truck

4

**GenH2 Technical details**

5

**H2 Projects in Mercedes-Benz do Brasil**

# Agenda

1

**Transformation path towards Zero Emission Transportation**

2

Daimler Truck Zero Emission portfolio

3

**GenH2 Truck**

| Hydrogen FuelCell Electric Truck from Daimler Truck

4

GenH2 Technical details

5

H2 Projects in Mercedes-Benz do Brasil

# Zero Emission in commercial vehicles depends on 3 important factors.

Policymakers on all levels strongly push towards global CO2-neutrality

## WINNING FORMULA

**FACTOR 1**  
Product Offering

X

**FACTOR 2**  
Infrastructure

X

**FACTOR 3**  
Cost Parity

=

**ZEV SUCCESS**



## PUSH FOR CO2-NEUTRALITY

**PARIS  
AGREEMENT &  
GLOBAL RACE  
TO NET ZERO  
BY LATEST 2050**

**EUROPEAN  
GREEN DEAL:  
-55% CO2  
EMISSIONS  
BY 2030**

**ADVANCED  
CLEAN FLEET:  
100% ZEV BY  
2036 IN  
CALIFORNIA**

**JAPAN:  
CARBON  
NEUTRALITY  
BY 2050**

# Flexibility and scale

Our strategy is flexible to meet different adoption speeds

## EXPECTED ZEV ADOPTION RATE

### NORTH AMERICA (CL. 6-8)

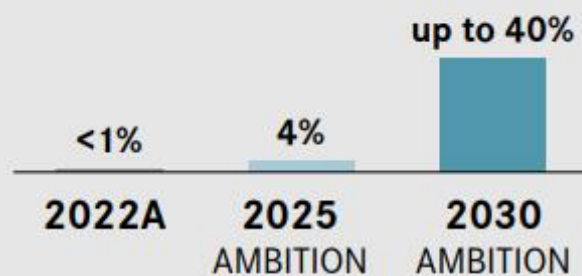

### EUROPE (HDT)

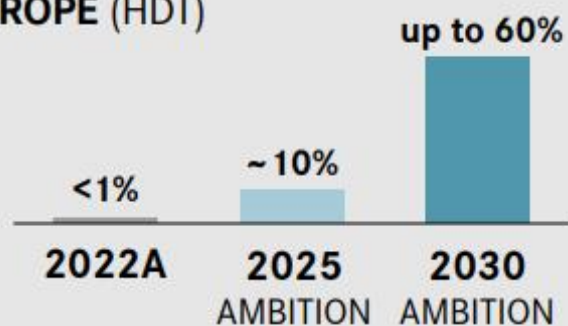

## OUR AMBITION

- ▶ ZEV leader in most of our focus markets by 2030
- ▶ Products ready when customers are
- ▶ Ramp-up ZEV capacity to meet demand and create scale

### EUROPE (CITY BUS)

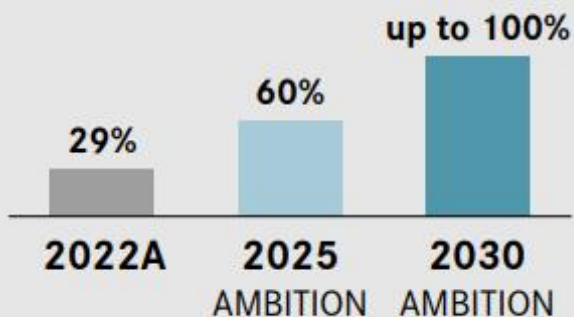

### JAPAN (LDT & MDT)



# Agenda

1

Transformation path towards Zero Emission Transportation

2

**Daimler Truck Zero Emission portfolio**

3

**GenH2 Truck**

| Hydrogen FuelCell Electric Truck from Daimler Truck

4

**GenH2 Technical details**

5

**H2 Projects in Mercedes-Benz do Brasil**

# Our zero emission vehicle portfolio combines different technologies

Different solutions are driven by customer needs

## INNER-CITY TRANSPORT & LOCAL DISTRIBUTION



## ON-HIGHWAY



## VOCATIONAL



 Battery Electric Vehicles

**H<sub>2</sub>** Fuel Cell Electric Vehicles

Today's focus

**H<sub>2</sub>** Combustion Engine

# Our future zero emission ePortfolio



**eActros**  
Heavy distribution  
*220 to 330 km*



**eActros LongHaul (BEV LH)**  
Longhaul  
*ca. 500 km*



**Fuel Cell**  
Longhaul  
*ca. 1.000 km*



# From fast to market to high volume production

Electrify at global scale across all brands with battery and fuel cell

## CREATING CUSTOMER VALUE

Upscaling passcar technology

CREATING SCALE

Truckified platforms

 eCanter 1.0, eCanter 2.0

 eCitaro

 eJouley

 eActros, eCascadia, eM2

 eActros 600

 GenH2  
H<sub>2</sub>



H<sub>2</sub>

'17

'21

'26/'27

# Agenda

1

Transformation path towards Zero Emission Transportation

2

Daimler Truck Zero Emission portfolio

3

**GenH2 Truck**

| Hydrogen FuelCell Electric Truck from Daimler Truck

4

GenH2 Technical details

5

H2 Projects in Mercedes-Benz do Brasil

# Mercedes-Benz GenH2 Truck

ON OUR  
HYDRO  
FU



# FuelCell - From idea to concept vehicle GenH2

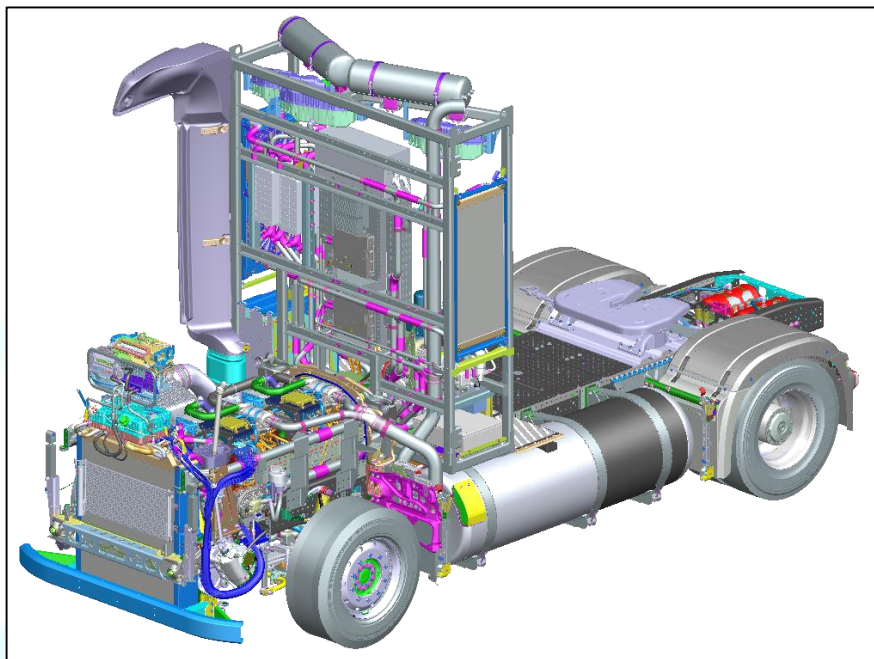

## Development & Design

*End of 2017 – Mid 2020*



## Vehicle build-up

*January – September 2020*



## World premiere

*September 2020*

# Mercedes-Benz GenH2 Trucks



- First series-produced trucks with hydrogen-based fuel cell drives planned for 2027
- The first prototypes of the Mercedes-Benz GenH2 Truck are already undergoing rigorous testing
- The development goal is a range of up to 1,000 kilometers and more.
- Same tough requirements of conventional trucks: 1.2 million km, 10 years service life or 25,000 operating hours

# Agenda

1

Transformation path towards Zero Emission Transportation

2

Daimler Truck Zero Emission portfolio

3

**GenH2 Truck**

| Hydrogen FuelCell Electric Truck from Daimler Truck

4

**GenH2 Technical details**

5

H2 Projects in Mercedes-Benz do Brasil

# Mercedes-Benz GenH2 - Technical overview

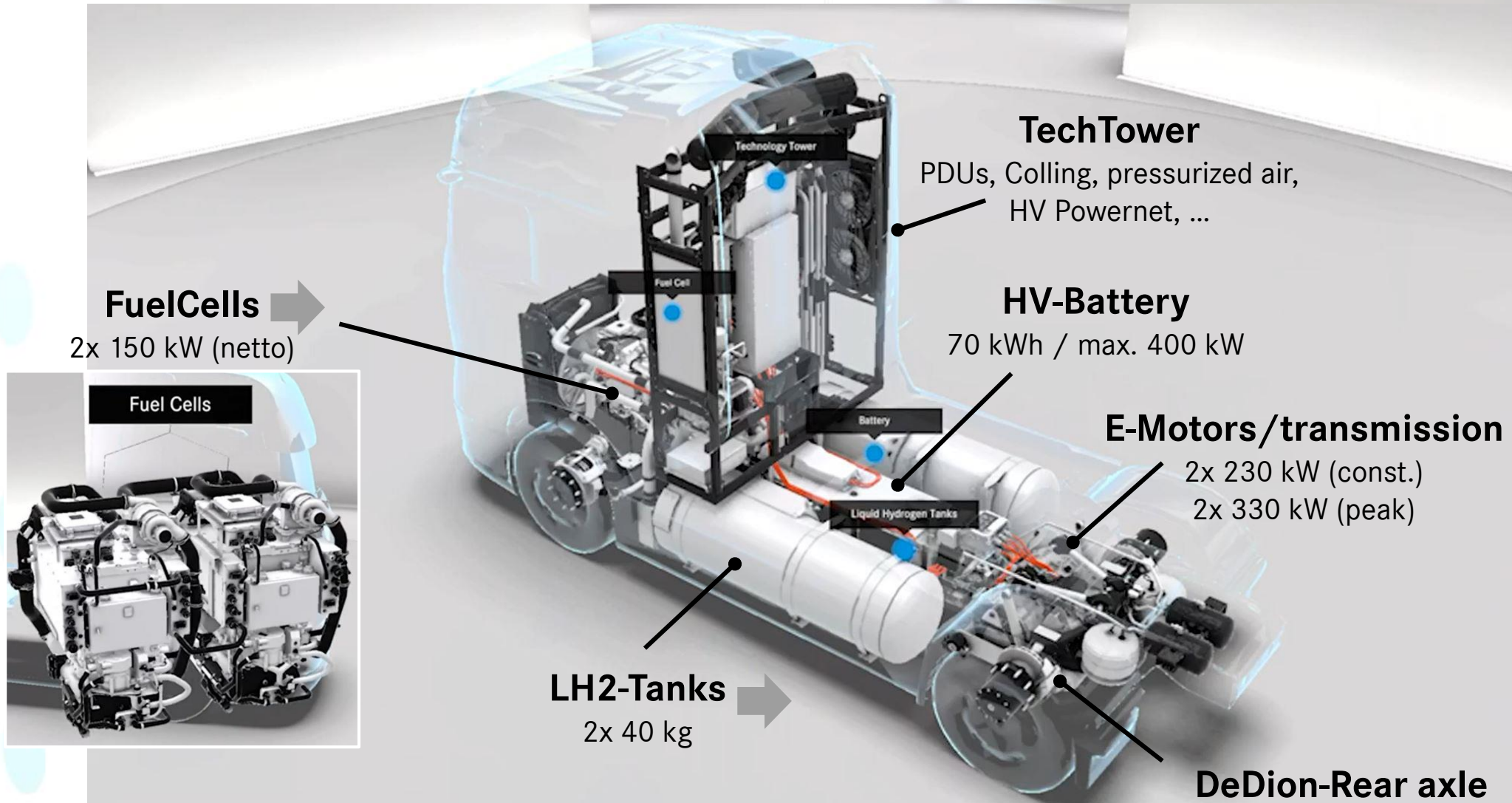

# Fuel Cell Truck – Functional Overview of Powertrain

**MAIN NEW COMPONENTS**

**BEV CARRY-OVER COMPONENTS**

*„A Fuel Cell Truck is an Energy Hybrid Vehicle“*

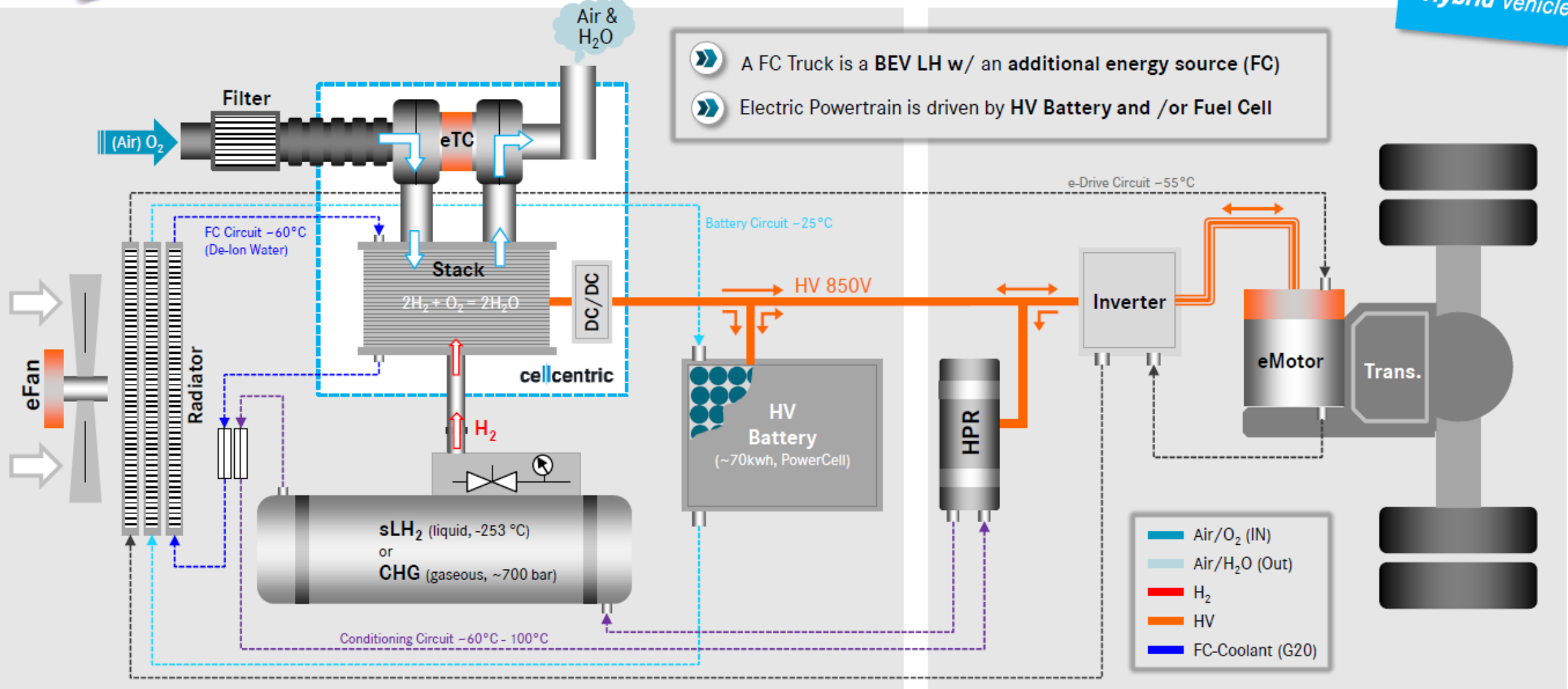



# FC-Twin System – consists 2x BZA 150 delivered from cellcentric plus a lot of additional components from DT

## FC-TWIN SYSTEM STRUCTURE

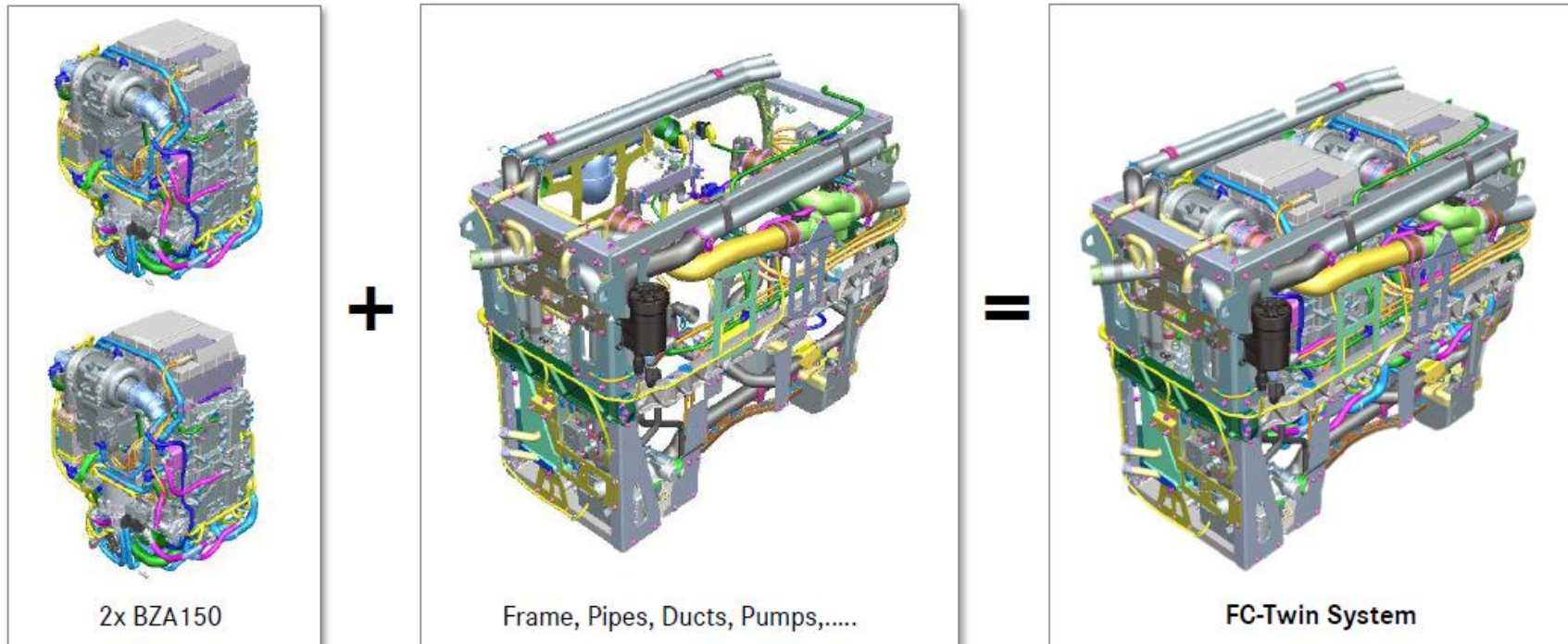

cellcentric

DAIMLER TRUCK

## KEY INFORMATION

- FC-Twin System consists of 2x BZA 150 – delivered from cellcentric to aggregate plant Gaggenau
- FC-Twin System also consists of a lot of additional components from DT like Frame, Pipes, Ducts, Pumps,...
- The FC-Twin System will be mounted in Gaggenau and then delivered to Vehicle plant Wörth for MB scope of delivery
- Discussion for global plant/delivery concept started

# Our favorized fuel concept: LH2 \*

\* Liquid Hydrogen

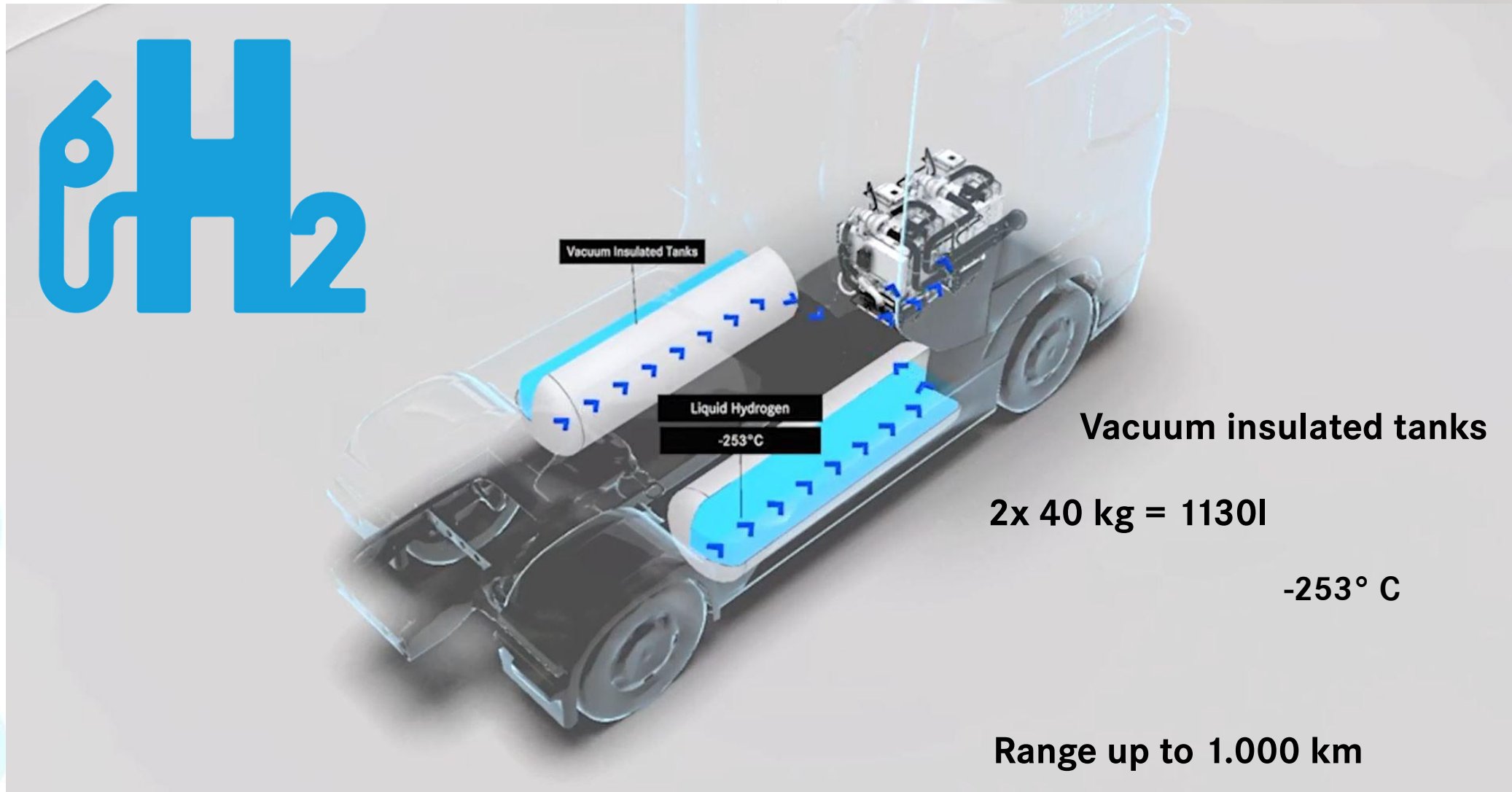

# Agenda

1

Transformation path towards Zero Emission Transportation

2

Daimler Truck Zero Emission portfolio

3

**GenH2 Truck**

| Hydrogen FuelCell Electric Truck from Daimler Truck

4

GenH2 Technical details







5

**H2 Projects in Mercedes-Benz do Brasil**

# Participation in Rota 2030 in partnership w/ ICTs & OEMs will allow CDT to start know-how build in Hydrogen technology w/ BR vocational

- MBBras in partnership with 2 Institutes of Science and Technology (ICTs), namely IPEN (Institute of Energy and Nuclear Research) and PUC-Rio (Pontifical Catholic University), as well as other 4 OEMs in the automotive sector (Stellantis, Bosch, Umicore and Ipiranga) **is conducting a research projects related to Hydrogen technology with support of Rota 2030 program.**
- MBBras is also conducting a project in partnership with PUC-Rio with support of AHK



Goals	 Intensify buildup of know-how related to hydrogen technology in Brazil	 Bring MBBras engineering closer to cutting-edge research with ICTs and other OEMs	 Research hydrogen-related solutions based on Brazilian characteristics (e.g. Ethanol)		
Projects – ROTA 2030	<p><b>Project name</b></p> <ul style="list-style-type: none"> <li>• “Increasing the efficiency of vehicular propulsion using onboard generated hydrogen: From the development of reformers to testing on propulsion systems”</li> <li>• “Measure engine power output of Accelo, with Hydrogen injection in Diesel engine</li> </ul>	<p><b>Sponsor</b></p>  	<p><b>Status</b></p>  Approved  Approved	<p><b>Duration (years)</b></p> <p>3</p> <p>1</p>	<p><b>Total invest. (TBRL)</b></p> <p>3552</p> <p>780</p>

Obrigado!

Contact:  
[joao.costa@daimlertruck.com](mailto:joao.costa@daimlertruck.com)



ON OUR WAY TO A  
HYDROGEN  
FUTURE

Backup

# Our purpose: For all who keep the world moving

We keep our heritage and lay the foundations for the future



**2025**

**2030**

**TRUCKS WILL REMAIN THE BACKBONE OF OUR ECONOMY**

**WE ARE THE VOICE OF OUR INDUSTRY**

**WE DRIVE THE TRANSFORMATION WITH GREAT ZEV PRODUCTS**

**WE SUPPORT OUR CUSTOMERS WITH THE RIGHT SOLUTIONS**



# Our ESG framework drives sustainability transformation

We have set clear ambitions and we are making good process

## ENVIRONMENT



Green products



Green production



Green supply chain

## SOCIAL



Our people



Human rights



Traffic safety

## GOVERNANCE

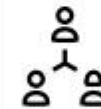

Responsible governance



Compliance & ESG risk management



Reporting & transparency